



# FROZEN CARBONATED BEVERAGE DISPENSER MODEL: 372 MIU (60Hz, 50Hz)

## SPECIFICATIONS

### AIR COOLED

### DIMENSIONS

#### DISPENSER

Width: 15.8" (400 mm)  
Depth: 25.2" (640 mm)  
Height: 31.5" (800 mm)

#### WEIGHT

##### DISPENSER

Operating: 217lbs (98kg)  
Empty: 199 lbs (90kg)

### CLEARANCE REQUIREMENTS

SIDES / BACK: 3 IN (76 MM) MINIMUM  
TOP: 12 IN (305 MM) MINIMUM

### CAPACITY

#### 60Hz / 50Hz

##### Barrel Volume

128 oz, (3785 mL)  
1800 oz/hr, (53,232 mL/hr)  
continuous, alternating barrels  
Recover time: 7 minutes

### REFRIGERATION

6,250 BTU / Hr, (6,594 KJ/hr) R-404A 60Hz / 50Hz

### SYRUP

Input: 70 - 72 PSIG (482 - 496 kPag)  
(2) FCB Base Syrup  
(4) Flavor Injected Syrup  
Bag-In-Box (BIB) syrup and connections

### MOTORS

Beater: (2) 1/6 HP, 0.85A Fan: 1/6 HP 0.43A (60Hz)  
Beater: (2) 1/6 HP, 0.81A Fan: 1/10 HP 0.36A (50Hz)

### WATER REQUIREMENTS

Fresh water, minimum 3/8" supply, 30 psi flowing (207 kPa)

### CO<sub>2</sub>

Supply pressure: 70-72 psig (483 - 496 kPa)  
Minimum 3/8" supply line

### ELECTRICAL REQUIREMENTS

#### 60Hz

215-245 VAC single phase; 3 wire, 20 amp;  
uses NEMA L6-20R receptacle



NEMA  
L6-20R

#### 50Hz

215-245 VAC single phase; 3 wire, 3000 W;  
Receptacle: Various (depending on market)  
Buck-boost Transformer required for operation outside this range

### GRAPHICS

#### Print

Duratrans 9 <sup>11</sup>/<sub>16</sub> in x 13 <sup>9</sup>/<sub>16</sub> in (246 mm x 345 mm)  
Flavor Card 4 <sup>7</sup>/<sub>8</sub> in x 3 <sup>1</sup>/<sub>2</sub> in (124 mm x 89 mm)

#### Digital

Touch Screen 5 inch (uses same digital graphics as 561)

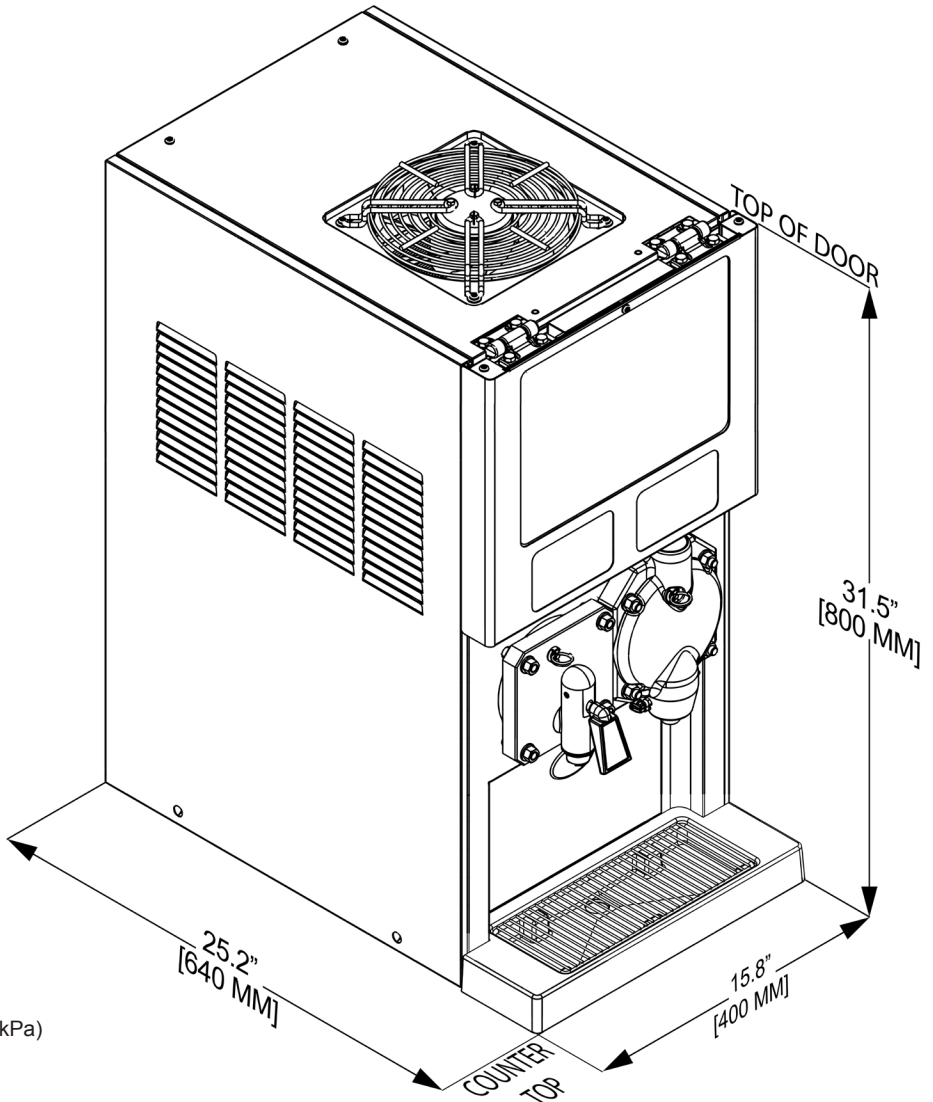

Intertek



Intertek

