



FROZEN CARBONATED BEVERAGE DISPENSER MODEL: 372 (60Hz)

SPECIFICATIONS

AIR COOLED DIMENSIONS

DISPENSER

Width: 15.8" (400 mm)
Depth: 25.2" (640 mm)
Height: 31.5" (800 mm)

WEIGHT DISPENSER

Operating: 212 lbs (96 kg)
Empty: 196 lbs (89 kg)

CLEARANCE REQUIREMENTS

SIDES OR BACK: 3.0 IN (76 MM) MINIMUM
TOP: 12.0 IN (305 MM) MINIMUM

CAPACITY

Barrel Volume: 128oz (3,785ml)
1800 oz/hr, 53,232mL/hr
continuous, alternating barrels
Recover time: 7min

REFRIGERATION

6250 BTU/Hr, R-404A

SYRUP

(2) FCB Base Syrup
Bag-In-Box (BIB) syrup and connections

MOTORS

Beater: (2) 1/6 HP (120w)
Fan: 1/6 HP (120w)

WATER REQUIREMENTS

Fresh water, minimum 3/8" supply, 30 psi flowing (207 kPa)

CO₂

Supply pressure: 70-72 psig (483 - 497 kPa)
Minimum 3/8" supply line

ELECTRICAL REQUIREMENTS

208-254 VAC single phase; 3 wire, 20 amp; (60 Hz)
uses NEMA L6-20R receptacle
Buck-boost transformer required for operation outside this range



NEMA
L6-20R

GRAPHICS

Duratrans: 9 11/16 in x 13 9/16 in (246 mm x 345 mm)
Flavor Cards: 4 7/8 in x 3 1/2 in (124 mm x 89 mm)

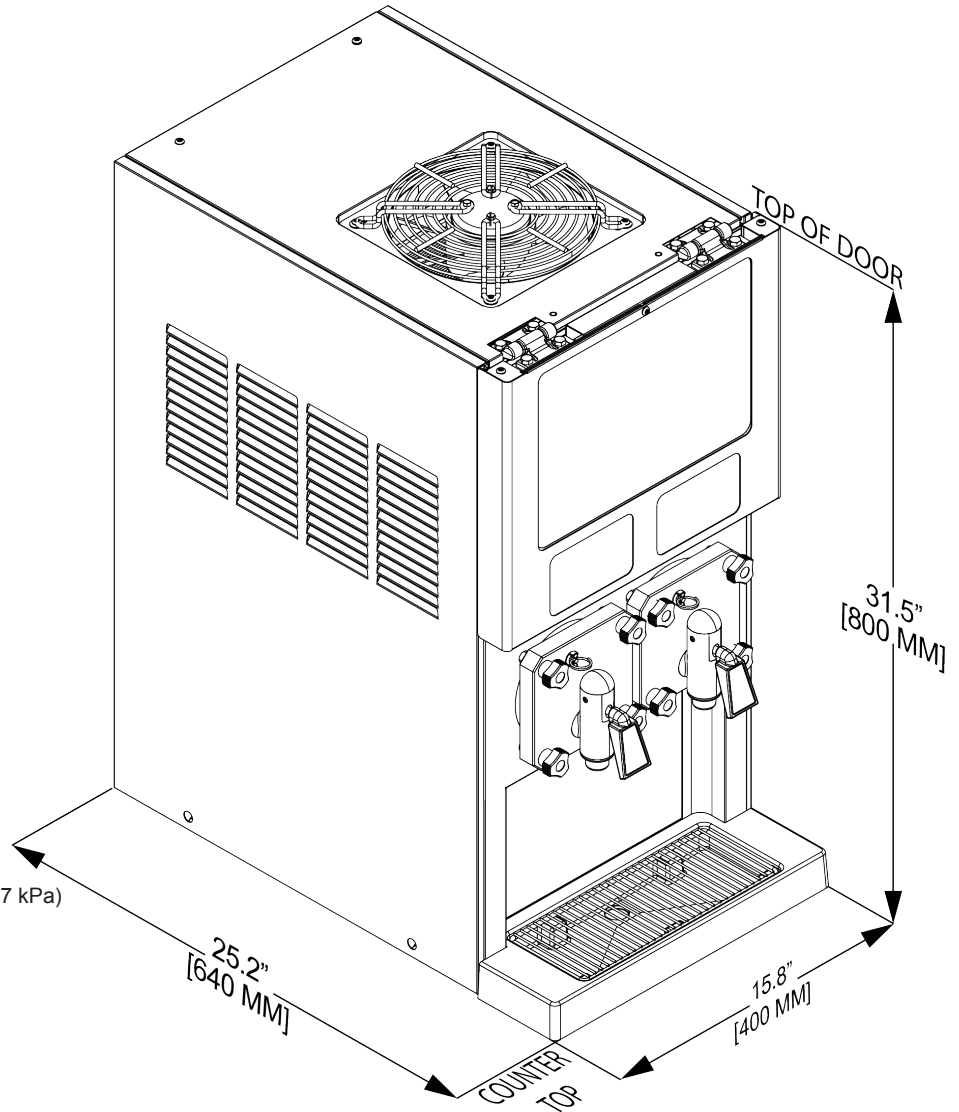

Intertek



Intertek

