



FROZEN CARBONATED BEVERAGE DISPENSER MODEL: 373 (60Hz)

SPECIFICATIONS

Air Cooled

DIMENSIONS

DISPENSER

Width: 20.1" (511 mm)
Depth: 25.2" (640 mm)
Height: 31.5" (800 mm)

WEIGHT

DISPENSER

Operating: 239 lbs (108kg)
Empty: 215 lbs (98kg)

CLEARANCE REQUIREMENTS

SIDES / BACK: 3 IN (76 MM) MINIMUM
TOP: 12 IN (305 MM) MINIMUM

CAPACITY

60Hz

Barrel Volume

128 oz, (3785 mL)
2750 oz/hr, (81,372 mL/hr)
continuous, alternating barrels
Recovery Time: 6 minutes

REFRIGERATION

6670 BTU / Hr, (7,037 KJ/hr) R-404A (60Hz)

SYRUP

Input: 70 - 72 PSIG (482 - 496 kPag)
(3) FCB Base Syrup
Bag-In-Box (BIB) syrup and connections

MOTORS

Beater: (3) 1/6 HP, 0.85A
Fan: 1/10 HP 0.35A (60Hz)

WATER REQUIREMENTS

Fresh water, minimum 3/8" supply, 30 psi flowing (207 kPa)

CO₂

Supply pressure: 70-72 psig (483 - 496 kPa)
Minimum 3/8" supply line

ELECTRICAL REQUIREMENTS

60Hz

215-245 VAC single phase; 3 wire, 20 amp;
uses NEMA L6-20R receptacle

Buck-boost transformer required for operation outside this range



NEMA
L6-20R

GRAPHICS

Duratrans 9 ¹¹/₁₆ in x 13 ⁹/₁₆ in (246 mm x 345 mm)
Flavor Card: 4 ⁷/₈ in x 3 ¹/₂ in (124 mm x 89 mm)

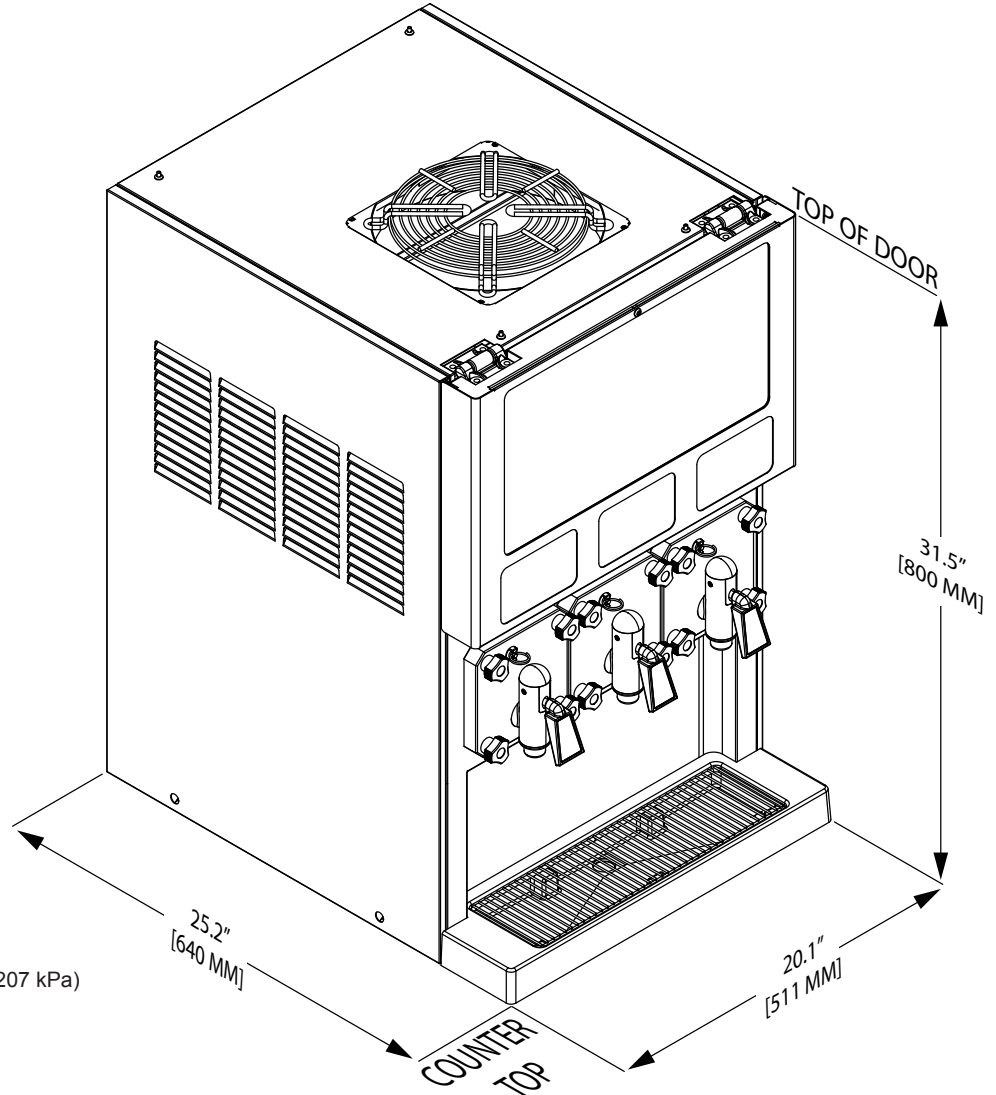

Intertek



Intertek

