



# FROZEN CARBONATED BEVERAGE DISPENSER MODEL: 772 TD (60Hz, 50Hz)

## SPECIFICATIONS

### AIR COOLED

### DIMENSIONS

#### DISPENSER

Width: 17" (432 mm)  
Depth: 32.5" (826 mm)  
Height: 41.4" (1052 mm)

#### WEIGHT

Operating: 321 lbs (145.6 kg)  
Empty: 298 lbs (135 kg)

#### CLEARANCE REQUIREMENTS

Sides or Back: 3 in. (76 mm) Minimum  
Top: **12-36 inches**: 12 in. (304 mm) Minimum with Side or Back Open-Air  
Conditions, 36 in. (914 mm) Minimum in Equipment Alcove.

#### CAPACITY

**Barrel Volume: 176oz** (5205 mm)  
4500 oz/hr. (133,081 mL/hr) continuous, alternating barrels  
Recover time: 4 Minutes

#### REFRIGERATION

15,000 BTU/Hr. (15,826 kJ/hr) R-404A (60 Hz)  
19,000 BTU/hr (20,046 kJ/hr), R-404A (50 Hz)

#### SYRUP

(2) FCB Base Syrup Flavors  
Bag-In-Box (BIB) syrup and connections

#### MOTORS

(60 Hz)	(50 Hz)
Beater: (2) 1/6 HP, 0.85 A	Beater: (2) 1/6 HP, 0.81 A
Fan: (1) 1/4 HP, 0.83 A	Fan: (1) 1/6 HP, 0.60 A

#### WATER REQUIREMENTS

Fresh water, minimum 3/8" supply, 30 psi flowing (207 kPa)  
Water Flow Rate: 1.5 oz/sec from Solution Module

#### CO<sub>2</sub>

Supply pressure: 70-72 psig (482.6 - 496.4 kPa)

#### ELECTRICAL REQUIREMENTS

215 to 245 VAC single phase; 3 wire, 20 amp; (3000 W) (50 Hz)  
uses NEMA #L-620R receptacle (60 Hz)  
Receptacle vary depending on market (50 Hz)  
Buck-boost transformer required for operation outside this ranges

#### GRAPHICS

DURATRANS: 17 3/4 in x 16 3/4 in (451 mm x 425 mm)  
Flavor Cards: 4 7/8 in x 3 1/2 in (124 mm x 89 mm)

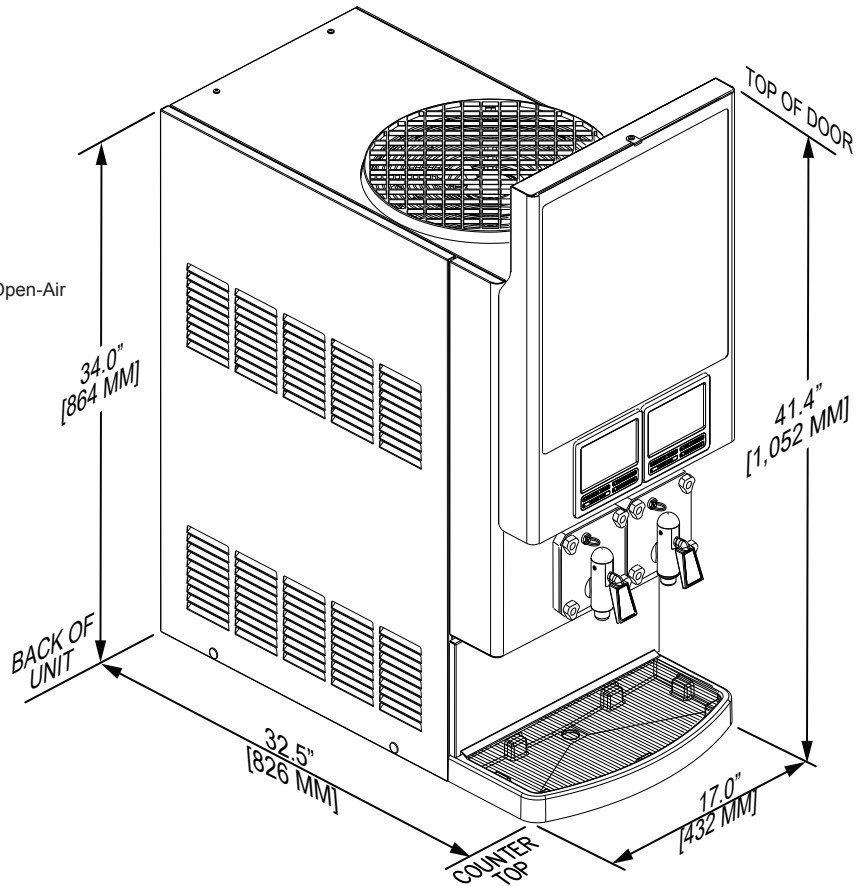

NEMA #L-6-20R (60 Hz)

